

Schrumpftechnik

Shrink technique

Technique de frettage

Shrink chuck for mounting
of solid carbide and HSS-tool shanks

Mandrin de frettage pour le serrage
de queue d'outils carbure de type HM et HSS

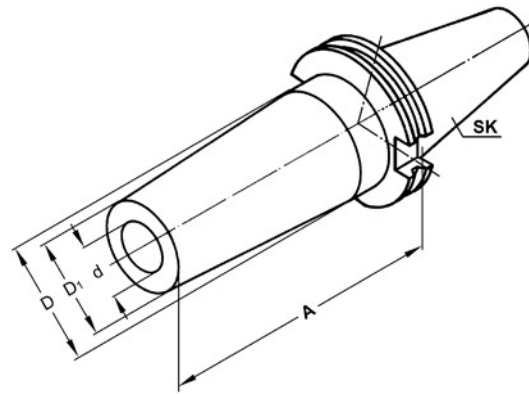

Bestell-Nr. Order no. Référence	SK	d	A	D1	D
403.70.03	SK 40	3	80	10	27
403.70.04	SK 40	4	80	15	27
403.70.05	SK 40	5	80	15	27
403.70.06	SK 40	6	80	20	27
403.70.08	SK 40	8	80	20	27
403.70.10	SK 40	10	80	24	32
403.70.12	SK 40	12	80	24	32
403.70.14	SK 40	14	80	27	35
403.70.16	SK 40	16	80	27	35
403.70.18	SK 40	18	80	33	42
403.70.20	SK 40	20	80	33	42
403.70.25	SK 40	25	100	44	53
403.70.32	SK 40	32	100	44	53
503.70.03	SK 50	3	80	10	27
503.70.04	SK 50	4	80	15	27
503.70.05	SK 50	5	80	15	27
503.70.06	SK 50	6	80	20	27
503.70.08	SK 50	8	80	20	27
503.70.10	SK 50	10	80	24	32
503.70.12	SK 50	12	80	24	32
503.70.14	SK 50	14	80	27	35
503.70.16	SK 50	16	80	27	35
503.70.18	SK 50	18	80	33	42
503.70.20	SK 50	20	80	33	42
503.70.25	SK 50	25	100	44	53
503.70.32	SK 50	32	100	44	53

Shrink chuck for mounting
of solid carbide and HSS-tool shanks

Mandrin de frettage pour le serrage
de queue d'outils carbure de type HM et HSS

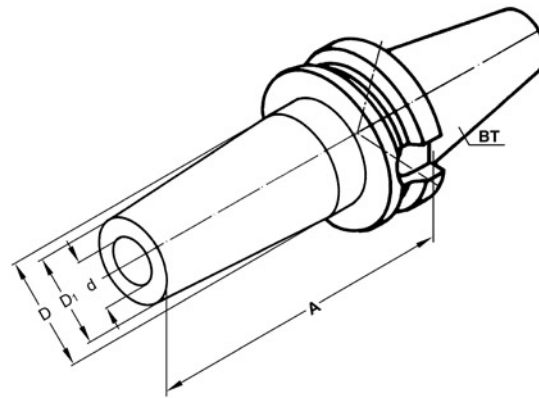

Bestell-Nr. Order no. Référence	BT	d	A	D1	D
406.70.03	BT 40	3	90	10	27
406.70.04	BT 40	4	90	15	27
406.70.05	BT 40	5	90	15	27
406.70.06	BT 40	6	90	20	27
406.70.08	BT 40	8	90	20	27
406.70.10	BT 40	10	90	24	32
406.70.12	BT 40	12	90	24	32
406.70.14	BT 40	14	90	27	35
406.70.16	BT 40	16	90	27	35
406.70.18	BT 40	18	90	33	42
406.70.20	BT 40	20	90	33	42
406.70.25	BT 40	25	100	44	53
406.70.32	BT 40	32	100	44	53
506.70.03	BT 50	3	90	10	27
506.70.04	BT 50	4	90	15	27
506.70.05	BT 50	5	90	15	27
506.70.06	BT 50	6	90	20	27
506.70.08	BT 50	8	90	20	27
506.70.10	BT 50	10	90	24	32
506.70.12	BT 50	12	90	24	32
506.70.14	BT 50	14	90	27	35
506.70.16	BT 50	16	90	27	35
506.70.18	BT 50	18	90	33	42
506.70.20	BT 50	20	90	33	42
506.70.25	BT 50	25	100	44	53
506.70.32	BT 50	32	100	44	53

Shrink chuck for mounting
of solid carbide and HSS-cutters

Mandrin de frettage pour le serrage
de queue d'outils carbure de type HM et HSS

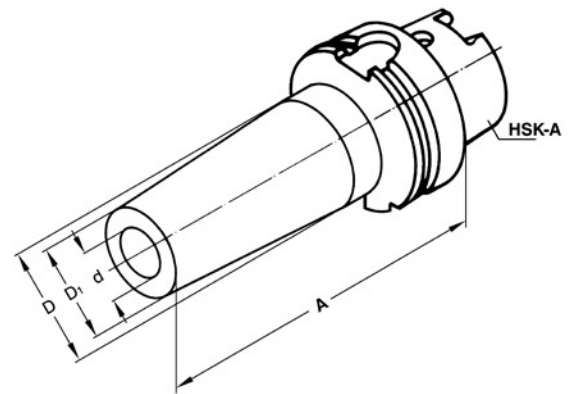

Bestell-Nr. Order no. Référence	HSK-A	d	A	D1	D
A40.70.03	HSK-A 40	3	70	10	32
A40.70.04	HSK-A 40	4	70	15	32
A40.70.05	HSK-A 40	5	70	15	32
A40.70.06	HSK-A 40	6	80	20	32
A40.70.08	HSK-A 40	8	80	20	34
A40.70.10	HSK-A 40	10	80	24	34
A40.70.12	HSK-A 40	12	90	24	34
A40.70.14	HSK-A 40	14	90	27	34
A40.70.16	HSK-A 40	16	90	27	34
A50.70.03	HSK-A 50	3	70	10	32
A50.70.04	HSK-A 50	4	70	15	32
A50.70.05	HSK-A 50	5	70	15	32
A50.70.06	HSK-A 50	6	80	20	32
A50.70.08	HSK-A 50	8	80	20	34
A50.70.10	HSK-A 50	10	85	24	34
A50.70.12	HSK-A 50	12	90	24	34
A50.70.14	HSK-A 50	14	90	27	34
A50.70.16	HSK-A 50	16	95	27	34
A50.70.18	HSK-A 50	18	95	33	42
A50.70.20	HSK-A 50	20	100	33	42

Shrink chuck for mounting
of solid carbide and HSS-tool shanks

Mandrin de frettage pour le serrage
de queue d'outils carbure de type HM et HSS

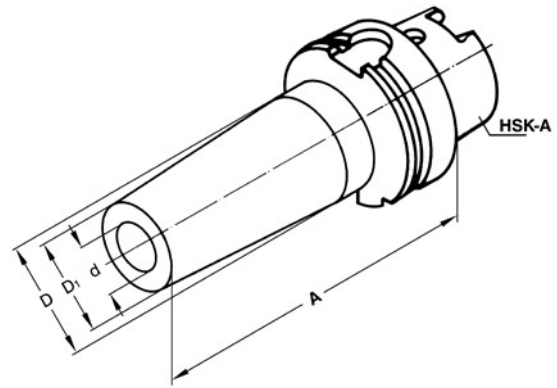

Bestell-Nr. Order no. Référence	HSK-A	d	A	D1	D
A63.70.03	HSK-A 63	3	70	10	32
A63.70.04	HSK-A 63	4	70	15	32
A63.70.05	HSK-A 63	5	70	15	32
A63.70.06	HSK-A 63	6	80	20	32
A63.70.08	HSK-A 63	8	80	20	34
A63.70.10	HSK-A 63	10	80	24	34
A63.70.12	HSK-A 63	12	90	24	34
A63.70.14	HSK-A 63	14	90	27	34
A63.70.16	HSK-A 63	16	90	27	34
A63.70.18	HSK-A 63	18	95	33	42
A63.70.20	HSK-A 63	20	100	33	42
A63.70.25	HSK-A 63	25	115	44	53
A80.70.06	HSK-A 80	6	85	20	32
A80.70.08	HSK-A 80	8	85	20	32
A80.70.10	HSK-A 80	10	90	24	32
A80.70.12	HSK-A 80	12	95	24	32
A80.70.14	HSK-A 80	14	95	27	32
A80.70.16	HSK-A 80	16	100	27	32
A80.70.18	HSK-A 80	18	100	33	42
A80.70.20	HSK-A 80	20	105	33	53
A80.70.25	HSK-A 80	25	115	44	70

Shrink chuck for mounting
of solid carbide and HSS-tool shanks

Mandrin de frettage pour le serrage
de queue d'outils carbure de type HM et HSS

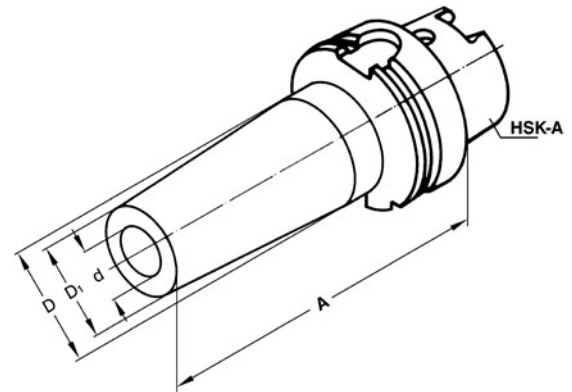

Bestell-Nr. Order no. Référence	HSK-A	d	A	D1	D
A100.70.06	HSK-A 100	6	85	20	32
A100.70.08	HSK-A 100	8	85	20	34
A100.70.10	HSK-A 100	10	90	24	32
A100.70.12	HSK-A 100	12	95	24	32
A100.70.14	HSK-A 100	14	95	27	34
A100.70.16	HSK-A 100	16	100	27	34
A100.70.18	HSK-A 100	18	100	33	42
A100.70.20	HSK-A 100	20	105	33	42
A100.70.25	HSK-A 100	25	115	44	53
A100.70.32	HSK-A 100	32	120	44	70

Shrink chuck for mounting
of solid carbide and HSS-tool shanks

Mandrin de frettage pour le serrage
de queue d'outils carbure de type HM et HSS

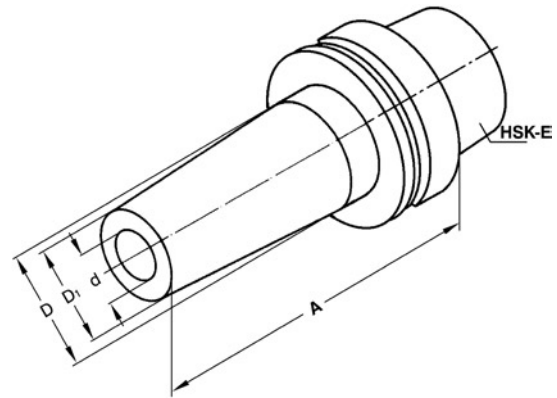

Bestell-Nr. Order no. Référence	HSK-E	d	A	D1	D
E40.70.03	HSK-E 40	3	70	10	32
E40.70.04	HSK-E 40	4	70	15	32
E40.70.05	HSK-E 40	5	70	15	32
E40.70.06	HSK-E 40	6	80	20	32
E40.70.08	HSK-E 40	8	80	20	34
E40.70.10	HSK-E 40	10	80	24	34
E40.70.12	HSK-E 40	12	90	24	34
E40.70.14	HSK-E 40	14	90	27	34
E40.70.16	HSK-E 40	16	90	27	34
E50.70.03	HSK-E 50	3	70	10	32
E50.70.04	HSK-E 50	4	70	15	32
E50.70.05	HSK-E 50	5	70	15	32
E50.70.06	HSK-E 50	6	80	20	32
E50.70.08	HSK-E 50	8	80	20	34
E50.70.10	HSK-E 50	10	85	24	34
E50.70.12	HSK-E 50	12	90	24	34
E50.70.14	HSK-E 50	14	90	27	34
E50.70.16	HSK-E 50	16	95	27	34
E50.70.18	HSK-E 50	18	95	33	42
E50.70.20	HSK-E 50	20	100	33	42

Shrink chuck for mounting
of solid carbide and HSS-tool shanks

Mandrin de frettage pour le serrage
de queue d'outils carbure de type HM et HSS

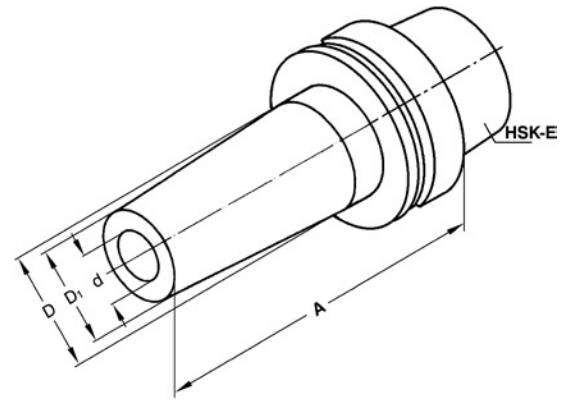

Bestell-Nr. Order no. Référence	HSK-E	d	A	D1	D
E63.70.03	HSK-E 63	3	70	10	32
E63.70.04	HSK-E 63	4	70	15	32
E63.70.05	HSK-E 63	5	70	15	32
E63.70.06	HSK-E 63	6	80	20	32
E63.70.08	HSK-E 63	8	80	20	34
E63.70.10	HSK-E 63	10	85	24	34
E63.70.12	HSK-E 63	12	90	24	34
E63.70.14	HSK-E 63	14	90	27	34
E63.70.16	HSK-E 63	16	95	27	34
E63.70.18	HSK-E 63	18	95	33	42
E63.70.20	HSK-E 63	20	100	33	42
E63.70.25	HSK-E 63	25	115	44	53